

PORTABLE LOW COST DIGITAL GAIT CYCLE ANALYSIS

ABSTRACT Project Number 4235

Gait Cycle analysis is the study of walking pattern of a living being. The way the human walks have been great interest to researchers in different disciplines, for example, the modeling of human body for robotic development and for making prosthetic replacement, perceiving actions and analyzing gait etc. This project aims at the analysis of human gait cycle analysis using specially designed potentiometer (displacement) sensors placed at ankle, knee and hip to measure angular displacements of these anatomical landmarks. These angular displacements are then calibrated in terms of voltage. These voltages are acquired by the controller (Zilog Microcontroller) and sent through Serial Port. The signal is then processed using computer software and graphs are plotted indicating the angular displacement with respect to the percentage of gait cycle.

Zilog Micro controller is used for its versatile inbuilt peripherals especially 10-bit ADC, UART, Infra Red Encoder/Decoder, I2C bus, which not only eases the signal acquisition hurdles, but also gives many future expansion to the project, like use of Infrared signals to discard the wires attached to the sensors and E2PROM storage by the use of I2C of results so that it can be used in telemetry.

Attached to a PC, this system can be used as portable low cost method for obtaining the temporal parameters of the gait. Rather than being intended as a replacement for more complicated systems used in Hospitals, this design is focused to deliver a support, to ascertain preliminary data, therefore reducing the time of hospitalization, for that purpose.

This project mainly targets the elimination of the use of cameras and markers in order to provide a low-tech solution for gait digitization.



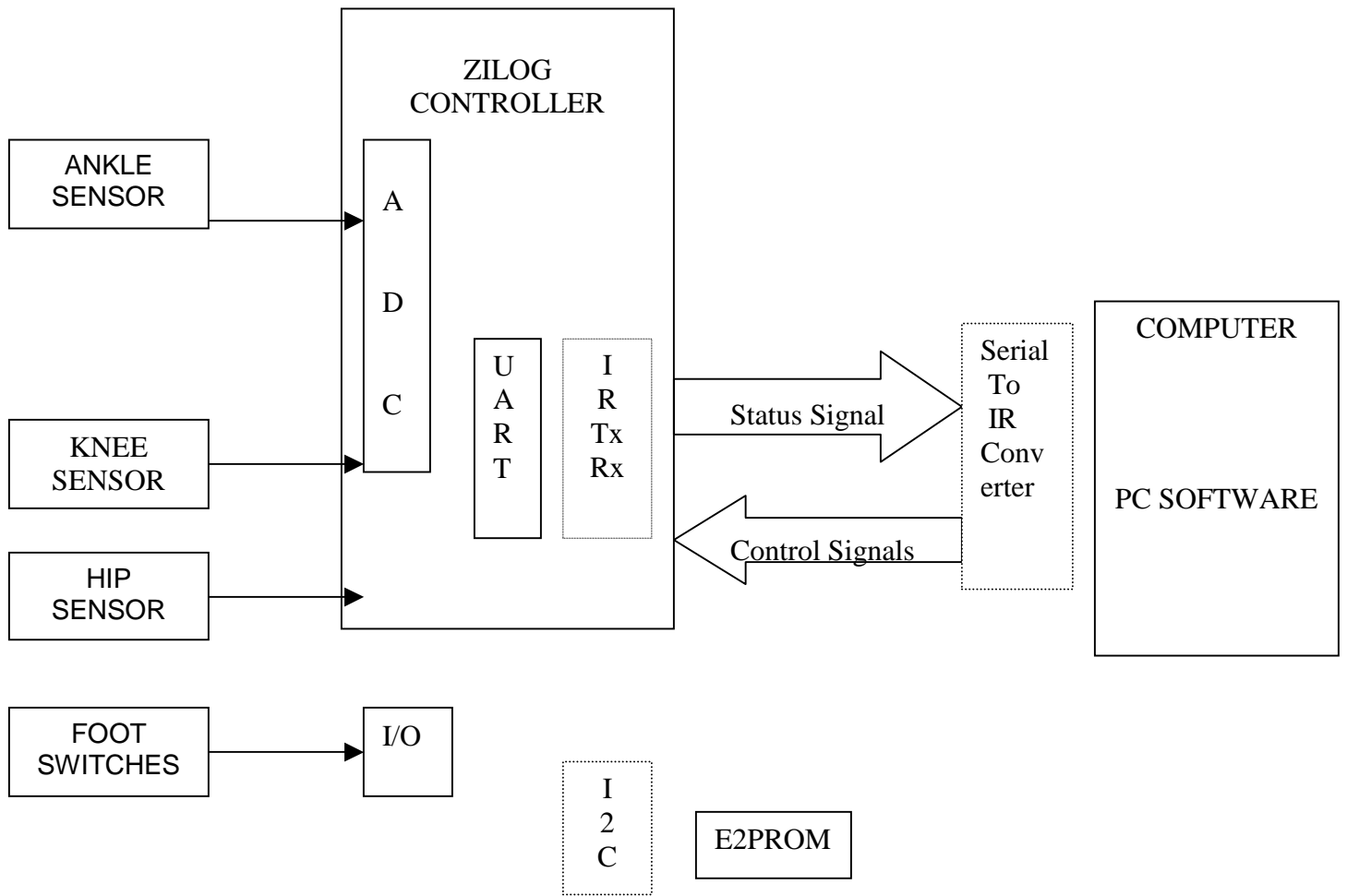

FIG: BLOCK DIAGRAM OF COMPUTERIZED GAIT CYCLE ANALYSIS UNIT

One of the output graphs is shown below.

