

AN1516

Liquid Level Control Using a Motorola Pressure Sensor

Prepared by: JC Hamelain
 Toulouse Pressure Sensor Laboratory
 Semiconductor Products Sector, Toulouse, France

INTRODUCTION

Motorola Discrete Products provides a complete solution for designing a low cost system for direct and accurate liquid level control using an ac powered pump or solenoid valve. This circuit approach which exclusively uses Motorola semiconductor parts, incorporates a piezoresistive pressure sensor with on-chip temperature compensation and a new solid-state relay with an integrated power triac, to drive directly the liquid level control equipment from the domestic 110/220 V 50/60 Hz ac main power line.

PRESSURE SENSOR DESCRIPTION

The MPXM2000 Series pressure sensor integrates on-chip, laser-trimmed resistors for offset calibration and temperature compensation. The pressure sensitive element is a patented, single piezoresistive implant which replaces the four resistor Wheatstone bridge traditionally used by most pressure sensor manufacturers.

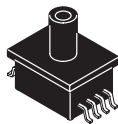

MPAK AXIAL PORT
 CASE 1320A

Depending on the application and pressure range, the sensor may be chosen from the following portfolio. For this application the MPXM2010GS was selected.

Device	Pressure Range	Application Sensitivity*
MPXM2010GS	0 to 10 kPa	± 0.01 kPa (1 mm H ₂ O)
MPXM2053GS	0 to 50 kPa	± 0.05 kPa (5 mm H ₂ O)
MPXM2102GS	0 to 100 kPa	± 0.1 kPa (10 mm H ₂ O)
MPXM2202GS	0 to 200 kPa	± 0.2 kPa (20 mm H ₂ O)

* after proper gain adjustment

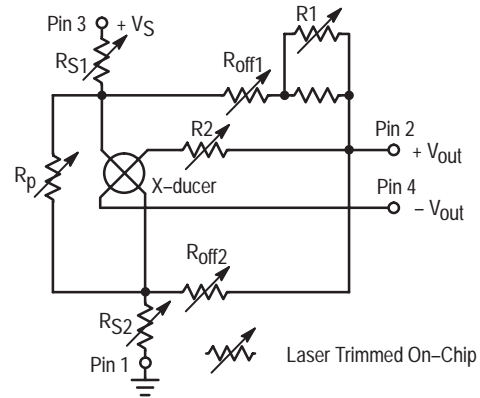

Figure 1. Pressure Sensor MPXM2000 Series

POWER OPTO is a trademark of Motorola Inc.

REV 2

POWER OPTO ISOLATOR MOC2A60 DESCRIPTION

The MOC2A60 is a new Motorola POWER OPTO™ isolator and consists of a gallium arsenide, infrared emitting diode, which is optically coupled to a zero-cross triac driver and a power triac. It is capable of driving a load of up to 2 A (rms) directly from a line voltage of 220 V (50/60 Hz).

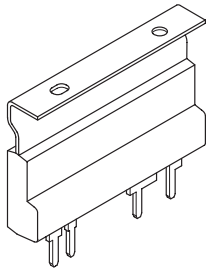

**CASE 417
PLASTIC
PACKAGE**

Device Schematic

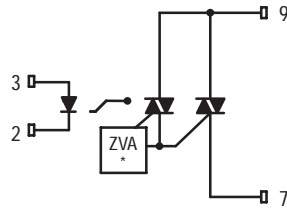

* Zero Voltage Activate Circuit

- 1, 4, 5, 6, 8. No Pin
- 2. LED Cathode
- 3. LED Anode
- 7. Main Terminal
- 9. Main Terminal

Figure 2. MOC2A60 POWER OPTO Isolator

SIGNAL CONDITIONING

When a full range pressure is applied to the MPXM2010GS, it will provide an output of about 20 mV (at an 8 V supply). Therefore, for an application using only a few percent of the pressure range, the available signal may be as low as a few hundred microvolts. To be useful, the sensor signal must be amplified. This is achieved via a true differential amplifier (A1 and A2) as shown in Figure 4. The GAIN ADJ (500 ohm) resistor, R_G, sets the gain to about 200.

The differential output of this stage is amplified by a second stage (A3) with a variable OFFSET resistor. This stage performs a differential to single-ended output conversion and references this output to the adjustable offset voltage. This output is then compared to a voltage (V_{REF} = 4 V at TP2) at the input of the third stage (A4).

This last amplifier is used as an inverted comparator amplifier with hysteresis (Schmitt trigger) which provides a logic signal (TP3) within a preset range variation of about 10% of the input (selected by the ratio R₉/(R₉ + R₇).

If the pressure sensor delivers a voltage to the input of the Schmitt trigger (pin 13) lower than the reference voltage (pin 12), then the output voltage (pin 14) is high and the drive current for the power stage MOC2A60 is provided. When the

sensor output increases above the reference voltage, the output at pin 14 goes low and no drive current is available.

The amplifier used is a Motorola MC33179. This is a quad amplifier with large current output drive capability (more than 80 mA).

OUTPUT POWER STAGE

For safety reasons, it is important to prevent any direct contact between the ac main power line and the liquid environment or the tank. In order to maintain full isolation between the sensor circuitry and the main power, the solid-state relay is placed between the low voltage circuit (sensor and amplifier) and the ac power line used by the pump and compressor.

The output of the last stage of the MC33179 is used as a current source to drive the LED (light emitting diode). The series resistor, R₈, limits the current into the LED to approximately 15 mA and guarantees an optimum drive for the power opto-triac. The LD1 (MFOE76), which is an infrared light emitting diode, is used as an indicator to detect when the load is under power.

The MOC2A60 works like a switch to turn ON or OFF the pump's power source. This device can drive up to 2 A for an ac load and is perfectly suited for the medium power motors (less than 500 watts) used in many applications. It consists of an opto-triac driving a power triac and has a zero-crossing detection to limit the power line disturbance problems when fast switching selfic loads. An RC network, placed in parallel with the output of the solid-state relay is not required, but it is good design practice for managing large voltage spikes coming from the inductive load commutation. The load itself (motor or solenoid valve) is connected in series with the solid-state relay to the main power line.

**EXAMPLE OF APPLICATION:
ACCURATE LIQUID LEVEL MONITORING**

The purpose of the described application is to provide an electronic system which maintains a constant liquid level in a tank (within ± 5 mm H₂O). The liquid level is kept constant in the tank by an ac electric pump and a pressure sensor which provides the feedback information. The tank may be of any size. The application is not affected by the volume of the tank but only by the difference in the liquid level. Of course, the maximum level in the tank must correspond to a pressure within the operating range of the pressure sensor.

LIQUID LEVEL SENSORS

Motorola has developed a piezoresistive pressure sensor family which is very well adapted for level sensing, especially when using an air pipe sensing method. These devices may also be used with a bubbling method or equivalent.

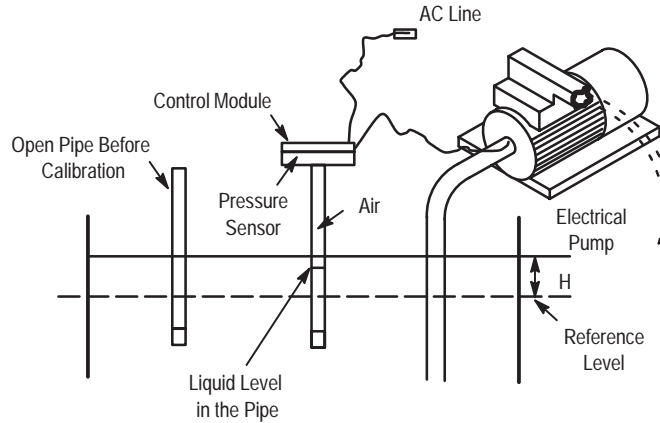

Figure 3. Liquid Level Monitoring

LEVEL SENSING THEORY

If a pipe is placed vertically, with one end dipped into a liquid and the other end opened, the level in the pipe will be exactly the same as the level in the tank. However, if the upper end of the pipe is closed off and some air volume is trapped, the pressure in the pipe will vary proportionally with the liquid level change in the tank.

For example, if we assume that the liquid is water and that the water level rises in the tank by 10 mm, then the pressure in the pipe will increase by that same value (10 mm of water).

A gauge pressure sensor has one side connected to the pipe (pressure side) and the other side open to ambient (in this case, atmospheric) pressure. The pressure difference which

corresponds to the change in the tank level is measured by the pressure sensor.

PRESSURE SENSOR CHOICE

In this example, a level sensing of 10 mm of water is desired. The equivalent pressure in kilo pascals is 0.09806 kPa. In this case, Motorola's temperature compensated 0–10 kPa, MPXM2010GS is an excellent choice. The sensor output, with a pressure of 0.09806 kPa applied, will result in $2.0 \text{ mV/kPa} \times 0.09806 = 0.196 \text{ mV}$.

The sensing system is designed with an amplifier gain of about 1000. Thus, the conditioned signal voltage given by the module is $1000 \times 0.196 \text{ mV} = 0.196 \text{ V}$ with 10 mm – H₂O pressure.

Table 1. Liquid Level Sensors

METHOD	SENSOR	ADVANTAGE	DISADVANTAGES
Liquid weight	Magneto-resistive	Low power, no active electronic	Low resolution, range limited
	Magneto-resistive	Very high resolution	Complex electronic
	Ultrasonic	Easy to install	Need high power, low accuracy
Liquid resistivity	No active electronic	No active electronic	Low resolution, liquid dependent
String potentiometer	Potentiometer	Low power, no active electronic	Poor linearity, corrosion
Pressure	Silicon sensors	Inexpensive good resolution, wide range measurements	Active electronic, need power

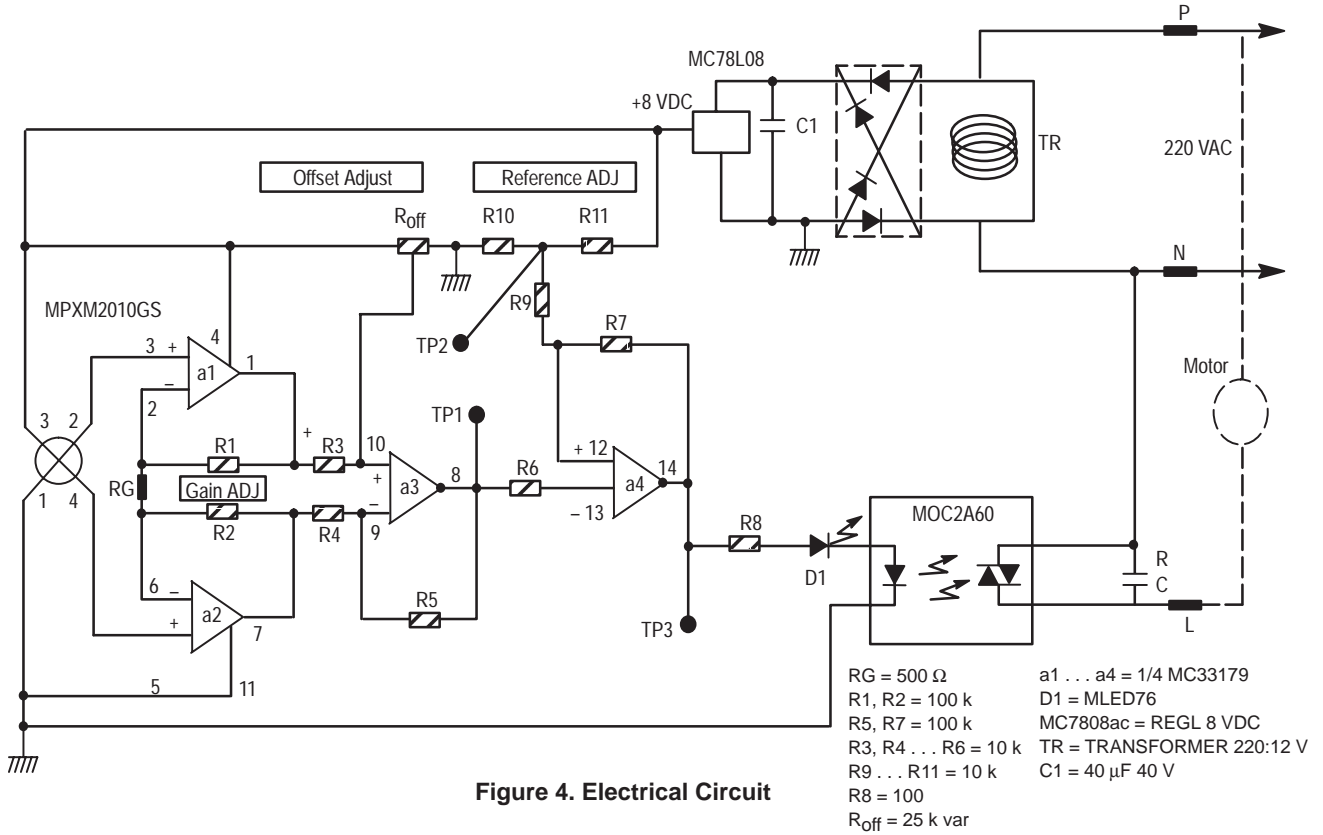
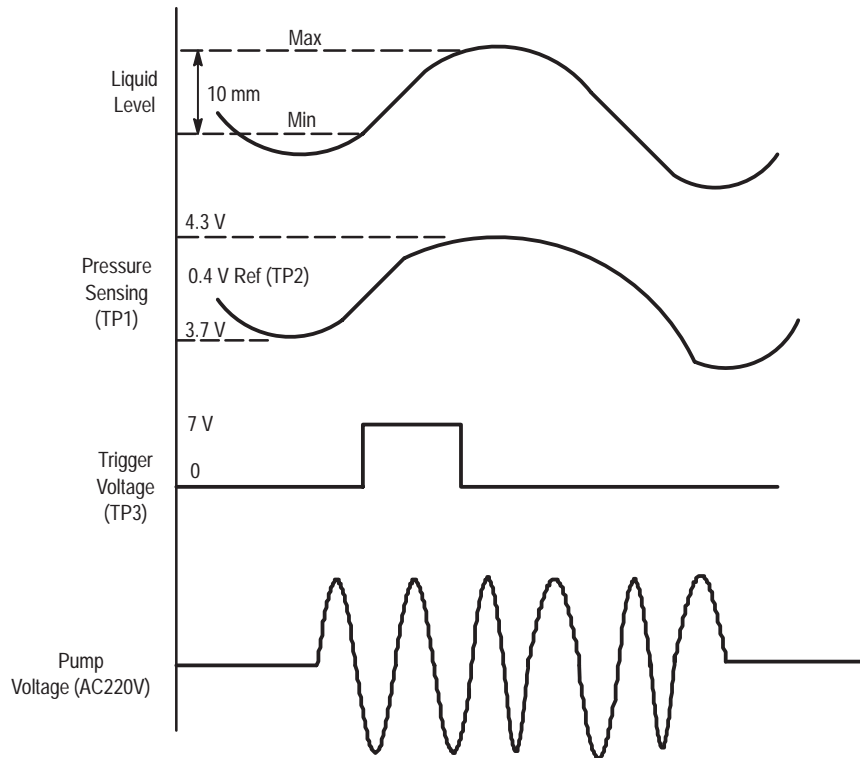

Figure 4. Electrical Circuit



Sensing for minimum level (pumping into the tank)

The sensing probe is tied to the positive pressure port of the sensor. The pump is turned on to fill the tank when the minimum level is reached.

Figure 5. Functional Diagram

LEVEL CONTROL MODES

This application describes two ways to keep the liquid level constant in the tank; first, by pumping the water out if the liquid level rises above the reference, or second, by pumping the water in if the liquid level drops below the reference.

If pumping water out, the pump must be OFF when the liquid level is below the reference level. To turn the pump ON, the sensor signal must be decreased to drop the input to the Schmitt trigger below the reference voltage. To do this, the sensing pipe must be connected to the NEGATIVE pressure port (back or vacuum side) of the sensor. In the condition when the pressure increases (liquid level rises), the sensor voltage will decrease and the pump will turn ON when the sensor output crosses the referenced level. As pumping continues, the level in the tank decreases (thus the pressure on the sensor decreases) and the sensor signal increases back up to the trigger point where the pump was turned OFF.

In the case of pumping water into the tank, the pump must be OFF when the liquid level is above the reference level. To turn ON the pump, the sensor signal must be decreased to drive the input Schmitt trigger below the reference voltage. To do this, the sensing pipe must be connected to the POSITIVE pressure port (top side) of the sensor. In this configuration when the pressure on the sensor decreases, (liquid level drops) the sensor voltage also decreases and the pump is turned ON when the signal exceeds the reference. As pumping continues, the water level increases and when the maximum level is reached, the Schmitt trigger turns the pump OFF.

ADJUSTMENTS

The sensing tube is placed into the water at a distance below the minimum limit level anywhere in the tank. The other

end of the tube is opened to atmosphere. When the tank is filled to the desired maximum (or minimum) level, the pressure sensor is connected to the tube with the desired port configuration for the application. Then the water level in the tank is the reference.

After connecting the tube to the pressure sensor, the module must be adjusted to control the water level. The output voltage at TP1 is preadjusted to about 4 V (half of the supply voltage). When the sensor is connected to the tube, the module output is ON (lighted) or OFF. By adjusting the offset adjust potentiometer the output is just turned into the other state: OFF, if it was ON or the reverse, ON, if it was OFF, (the change in the tank level may be simulated by moving the sensing tube up or down).

The reference point TP2 shows the ON/OFF reference voltage, and the switching point of the module is reached when the voltage at TP1 just crosses the value of the TP2 voltage. The module is designed for about 10 mm of difference level between ON and OFF (hysteresis).

CONCLUSION

This circuit design concept may be used to evaluate Motorola pressure sensors used as a liquid level switch. This basic circuit may be easily modified to provide an analog signal of the level within the controlled range. It may also be easily modified to provide tighter level control (± 2 mm H₂O) by increasing the gain of the first amplifier stage (decreasing RG resistor).

The circuit is also a useful tool to evaluate the performance of the power optocoupler MOC2A60 when driving ac loads directly.

NOTES

Freescale Semiconductor, Inc.

Motorola reserves the right to make changes without further notice to any products herein. Motorola makes no warranty, representation, or guarantee regarding the suitability of its products for any particular purpose, nor does Motorola assume any liability arising out of the application or use of any product or circuit, and specifically disclaims any and all liability, including without limitation consequential or incidental damages. "Typical" parameters can and do vary in different applications and actual performance may vary over time. All operating parameters, including "Typicals", must be validated for each customer application by customer's technical experts. Motorola does not convey any license under its patent rights nor the rights of others. Motorola products are not designed, intended, or authorized for use as components in systems intended for surgical implant into the body, or other applications intended to support or sustain life, or for any other application in which the failure of the Motorola product could create a situation where personal injury or death may occur. Should Buyer purchase or use Motorola products for any such unintended or unauthorized application, Buyer shall indemnify and hold Motorola and its officers, employees, subsidiaries, affiliates, and distributors harmless against all claims, costs, damages, and expenses, and reasonable attorney fees arising out of, directly or indirectly, any claim of personal injury or death associated with such unintended or unauthorized use, even if such claim alleges that Motorola was negligent regarding the design or manufacture of the part. Motorola and the Stylized M Logo are registered in the US Patent & Trademark Office. All other product or service names are the property of their respective owners. Motorola, Inc. is an Equal Opportunity/Affirmative Action Employer.

© Motorola, Inc. 2002.

How to reach us:

USA/EUROPE/Locations Not Listed: Motorola Literature Distribution; P.O. Box 5405, Denver, Colorado 80217. 1-303-675-2140 or 1-800-441-2447

JAPAN: Motorola Japan Ltd.; SPS, Technical Information Center, 3-20-1, Minami-Azabu, Minato-ku, Tokyo 106-8573 Japan. 81-3-3440-3569

ASIA/PACIFIC: Motorola Semiconductors H.K. Ltd.; Silicon Harbour Centre, 2 Dai King Street, Tai Po Industrial Estate, Tai Po, N.T. Hong Kong. 852-26668334

Technical Information Center: 1-800-521-6274

HOME PAGE: <http://www.motorola.com/semiconductors/>



MOTOROLA

**For More Information On This Product,
Go to: www.freescale.com**

AN1516/D