

Emaze

Electric Field Animal Locomotion Function Remote Monitoring System

Project number: **FZ1600**

Abstract

This project is to build a locomotion function monitoring system for mice or rats using Freescale's Electric Field Imaging Device and ZigBee RF transceiver.

Locomotion function is one of the important behavior parameters in animal research for human neurodegenerative diseases such as Parkinson's disease, Huntington's disease, and Alzheimer's disease. Neurodegenerative animal models have been well-established in rodents. Animal models with such diseases exhibit the characteristic motoric deficits including declined movement activity, decreased movement speed, and reduced traveling distance. With an effective drug treatment, the animal locomotion function could be recovered to a great extent. Therefore, to automate logging of the animal's locomotion function is essential in the pharmaceutical laboratory.

The system contains a remote data acquiring unit and a data analysis unit. The data acquiring unit is comprised of an electrode grid plate placed in a normal mouse cage, a low frequency sine wave electric field generator using a Freescale MC33794 and an IEEE 802.15.4 compliant RF transceiver using Freescale Sensor Application Reference Design (SARD) board. The comb-like electrodes are in an inter-digitated configuration arranged in 5 rows by 4 columns on the electrode plate. A 120 KHz sine wave signal is multiplexed to each of the electrodes in about 10 ms durations. A thin vinyl film is placed on top of the electrode plate to avoid direct contact with the animal's feet. As the animal steps on top of the electrode, it increases the capacity between the corresponding underlying electrode and the ground. As the result, the 120 KHz sine wave signal is shunt to ground and the instant voltage is dropped on that electrode. The voltages on all electrodes are digitized and forwarded to the analysis unit through the RF link. The data analysis unit is a ZigBee transceiver evaluation board (EVB) connected to a PC host by a serial cable. A program on the analysis unit compares all electrode voltages and determines the location of the animal. The animal location information is recorded and displayed on the PC screen. Based on the location and data collection timestamp, the animal's traveling speed and distance can also be calculated. Although the project demonstrates the locomotion monitor in one cage, multiple cages simultaneously monitoring can be very easy to achieve due to the advantages of the ZigBee RF transmission collision avoidance feature.

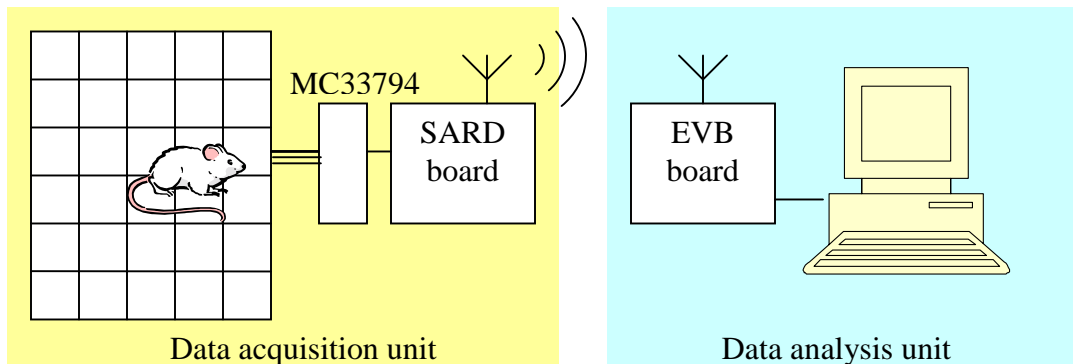

Emaze system contains a data acquisition unit and data analysis unit

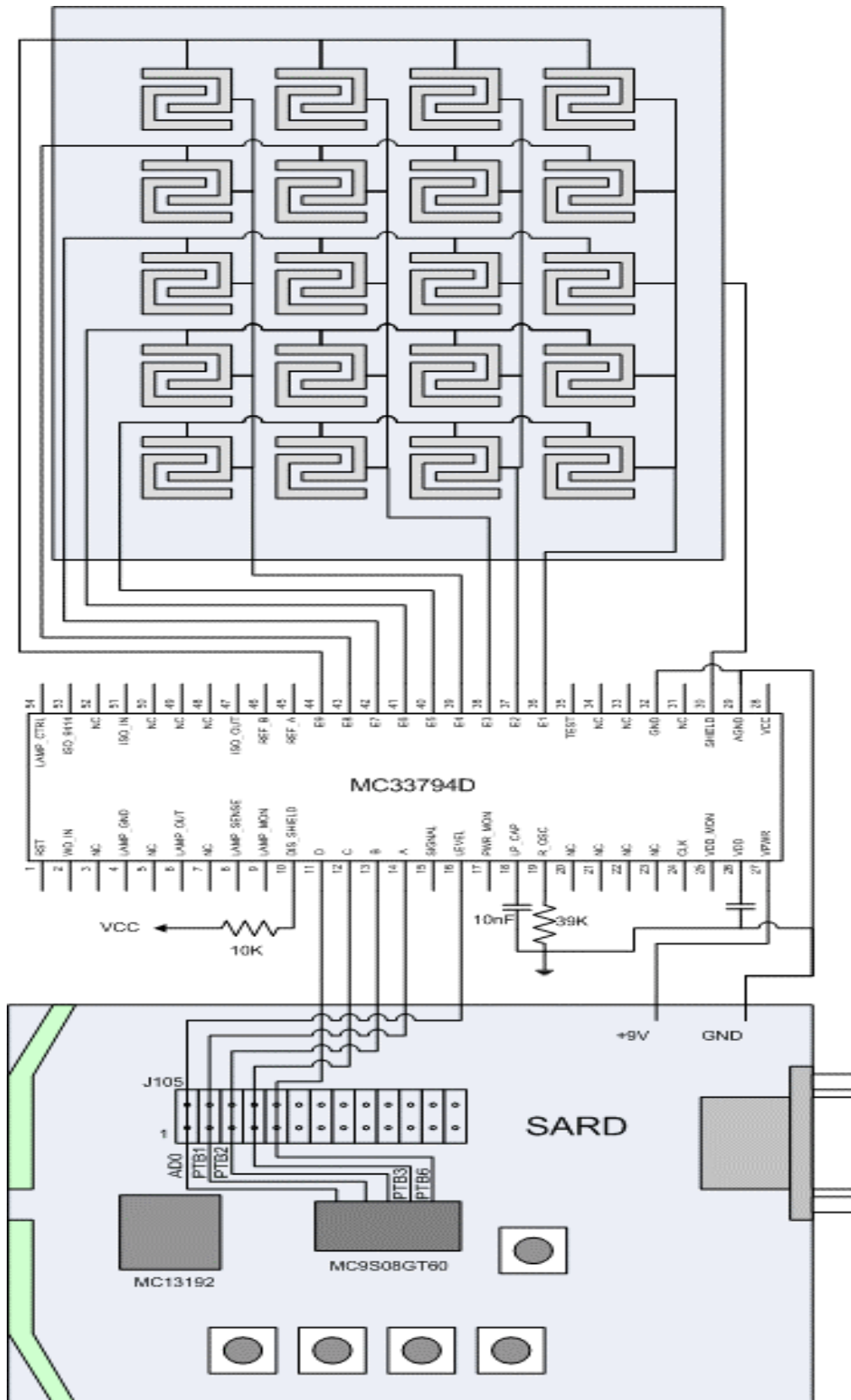

The data acquisition unit contains an electrode plate, e-field sensor and a SARD.

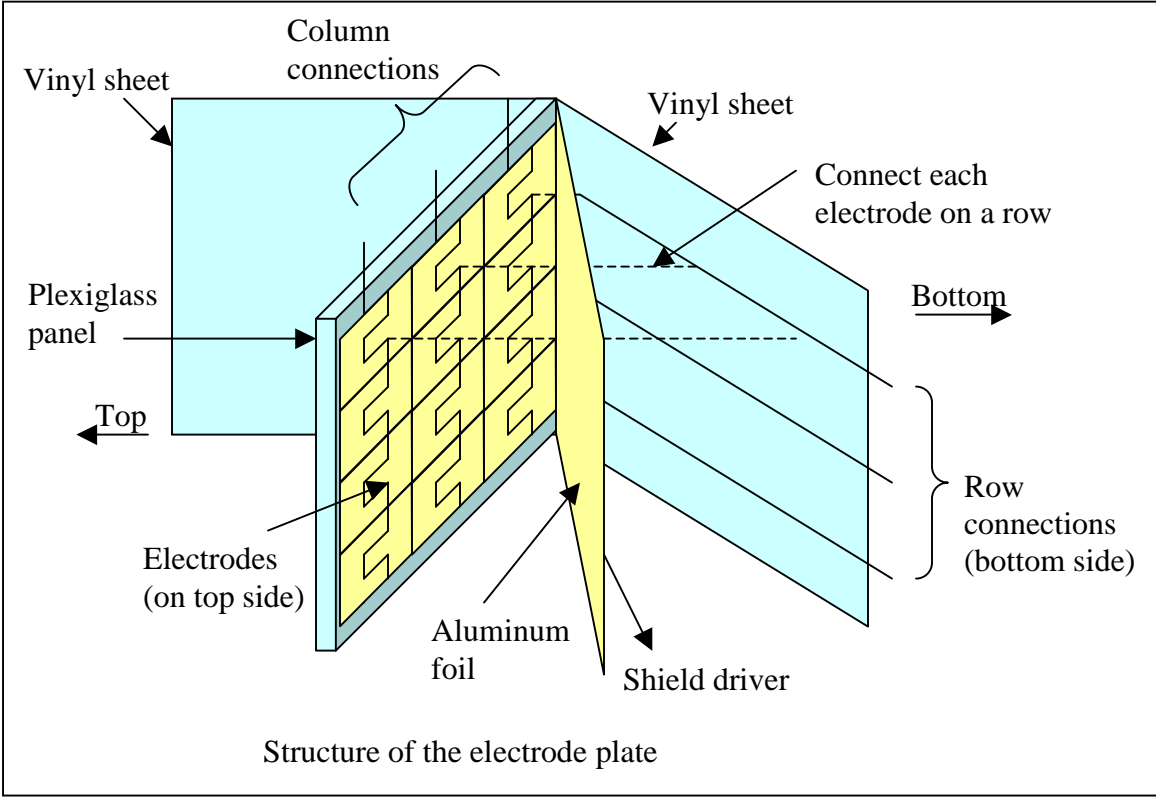



The data acquisition unit placed on the bottom of the mice cage.



The food supply grid does not get in the way of the data acquisition unit.