

## Backpack Water Level Monitor

Hiking has become an increasingly popular form of recreation, since the biggest expense is only a comfortable pair of sturdy shoes. To avoid dehydration, it's important to bring an ample water supply in either a bottle or a backpack with a built-in reservoir, known as a hydration pack. I recently purchased a 3-liter pack, and found it somewhat annoying that it is difficult to know how much water is left in it, or how much longer it will last.

This seemed like a perfect application for the E-Field sensor. I could place an array of sensing pads along the outside of the reservoir, and have a display that shows the current water level. By keeping track of time, I could also compute an estimate of how much longer the remaining water would last, at the present consumption rate. The complete system would have to be as light as possible, and the display would have to be in a convenient location and readable in direct sunlight.

The hardware I came up with uses the MC33794 E-Field Imaging IC along with a MC68HC08QY2 MCU. A MAX232 serial level converter is included for program downloading, but isn't needed for actual operation. A pair of 7-segment LEDs driven by two 74HC164 serial-to-parallel shift registers sit in a small remotely-mountable box, along with a pushbutton that activates them to display the level and time remaining. The whole system is powered by a set of four lithium coin cells, with a low-power voltage regulator supplying 5V power.

The software is relatively straightforward, consisting of a set of measurement and display routines. The water level is determined by looking for the largest difference in capacitance between adjacent sensors. This level is tracked over time, since it may change as the water sloshes around in the reservoir. This variation in level is used to determine whether the actual level is directly over one of the sensors, or between a pair of them; this effectively doubles the measurement resolution. This level is debounced and displayed on demand.

Whenever the level changes, the elapsed time is stored, and the average time for a level change is multiplied by the actual level to determine an estimate of the time remaining. I used a novel approach to accurately measure the MCU's auto-wakeup timer period, so that I could use it to keep track of time. Since the water consumption could change due to varying terrain, temperature, exertion level or other factors, the displayed time is only an approximate guideline.

### Code Sample

```
FindMax      equ      *
;
; Find the highest and 2nd highest difference value,
; and make sure they meet the threshold criteria.
;
; The highest value corresponds to the electrode pair
; located at the current water level.
;
; If all the differences are below the empty threshold,
; then the reservoir must be empty. Since the top
; electrode is above the highest water level, this
; case never happens if the reservoir is full.
;
```

```

; stack: 0 bytes
;
;   clr   MaxVal           ;Current max value
;   clr   MaxVal2         ;Previous max value
;   ldx   #NUMELEC-1
;
FindLp1   lda   MeasTbl,x   ;Get a value
;   cmp   MaxVal          ;found a new maximum?
;   blo   FindLp2         ;no
;
;   mov   MaxVal,MaxVal2   ;copy old value
;   sta   MaxVal          ;save new value
;   stx   MaxLoc          ;and location of new value
;
FindLp2   dbnzx FindLp1     ;yes
;
;   lda   MaxVal
;   cmp   #DIFFTH0        ;Highest value below empty threshold?
;   blo   FindEmp         ;yes, reservoir must be empty
;   cmp   #DIFFTH1        ;Highest value above threshold?
;   blo   FindEr1         ;no
;   sub   MaxVal2          ;Delta between highest and 2nd highest
;   cmp   #DIFFTH2        ; above threshold?
;   blo   FindEr2         ;no
;
;   lda   MaxLoc          ;Get location of max value (1-8)
;   sta   CurLvl          ;and update current water level
;   clc
;   rts
;
FindEmp   clr   CurLvl     ;Set current water level to 0
;   clc
;   rts
;
FindEr1   lda   #E_FIND1   ;Error: highest difference value too small
;   sec
;   rts
;
FindEr2   lda   #E_FIND2   ;Error: difference delta value too small
;   sec
;   rts

```

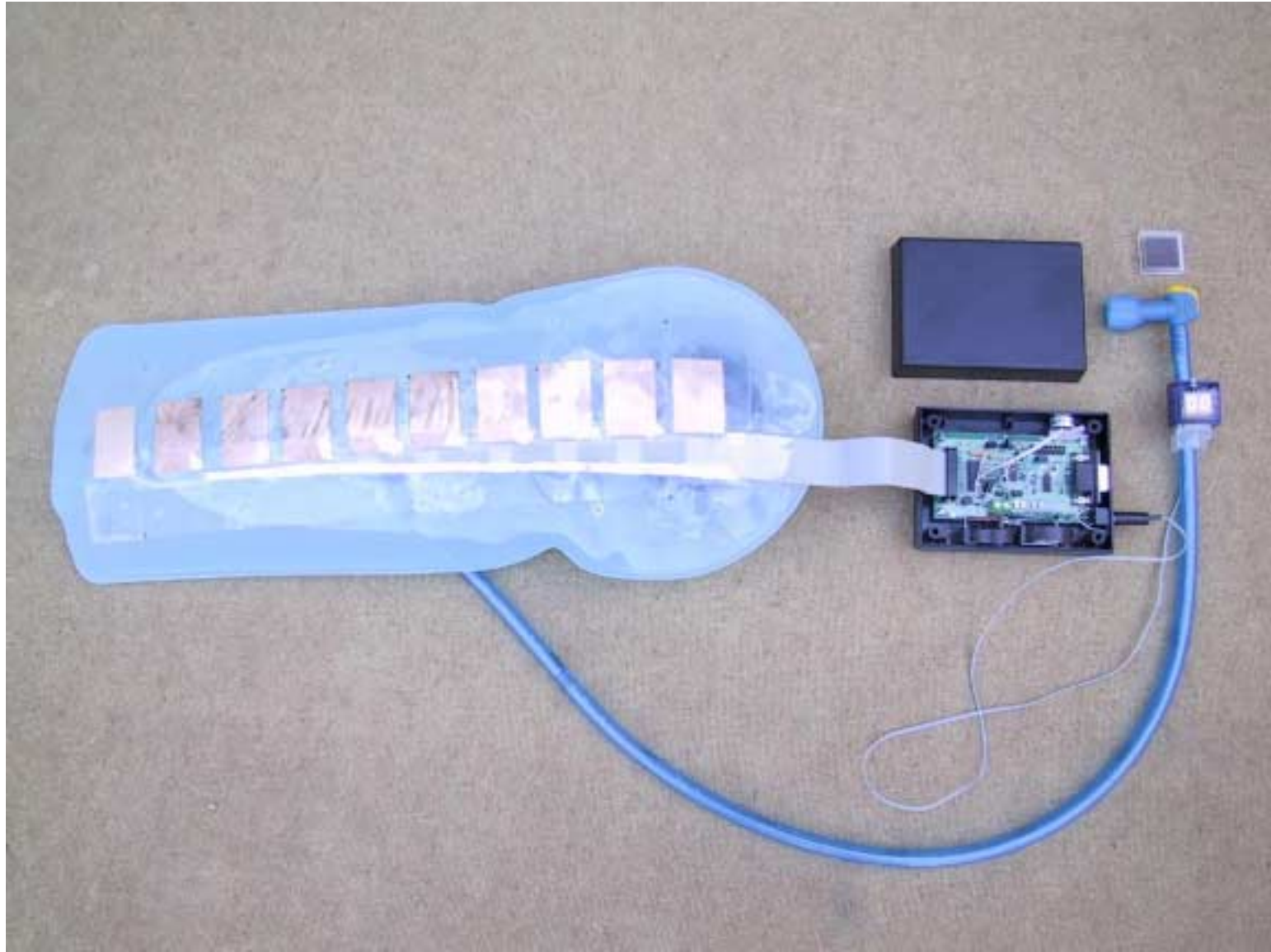

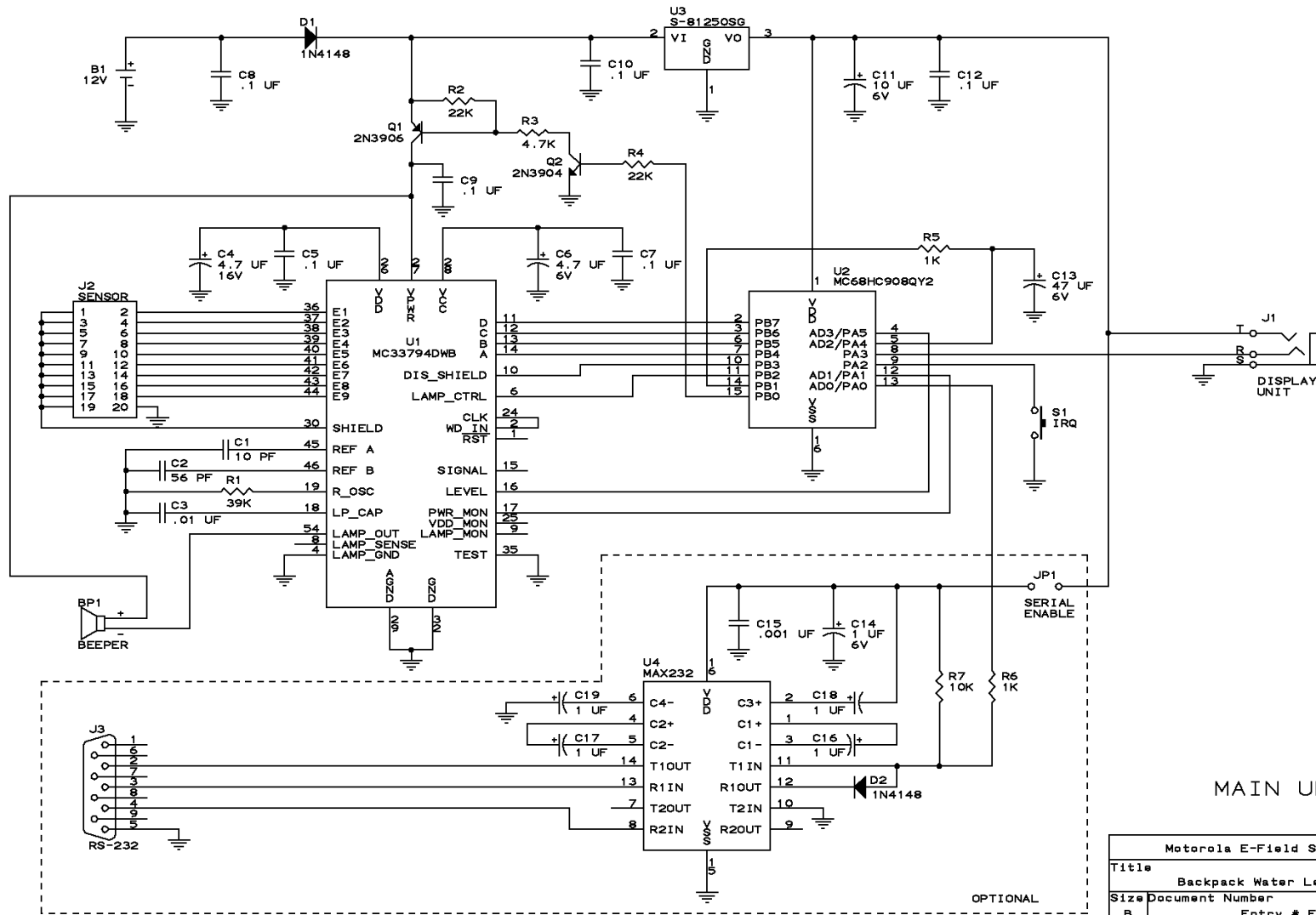

MAIN UNIT

Motorola E-Field Sensor Contest		
Title Backpack Water Level Monitor		
Size B	Document Number Entry # EF3398	REV 1
Date: September 30, 2003 Sheet 1 of 2		

Block  
Diagram

Motorola E-Field Sensor  
Contest – Entry # EF3398

